

**EU205 – EU205/B
(EU300 – EU300B)**

NOTICE: This document contains references to "PVR". Please note that PVR was acquired by Agilent Technologies in January 2012. For more information about these products and support, go to www.agilent.com/chem/vacuum.

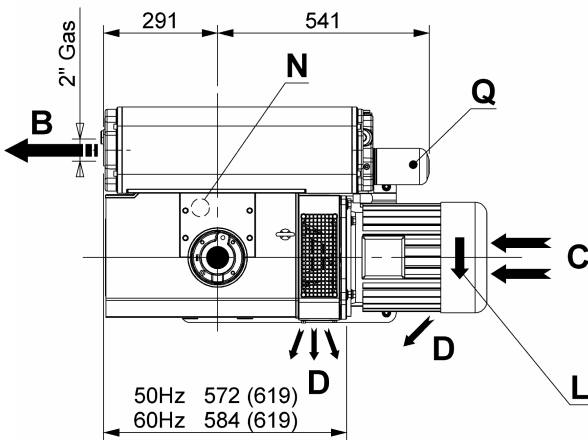
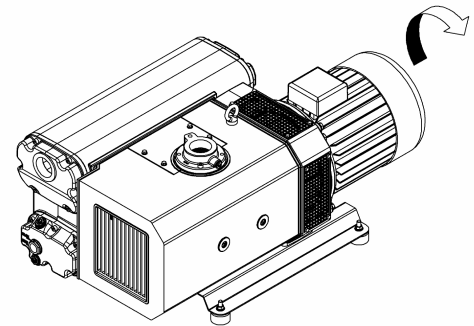
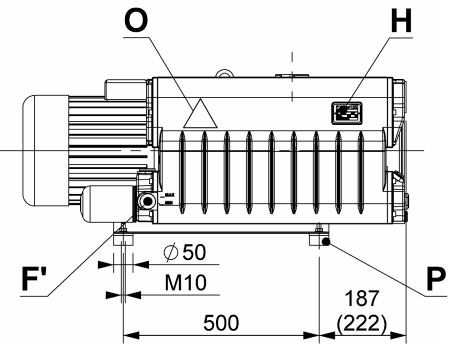
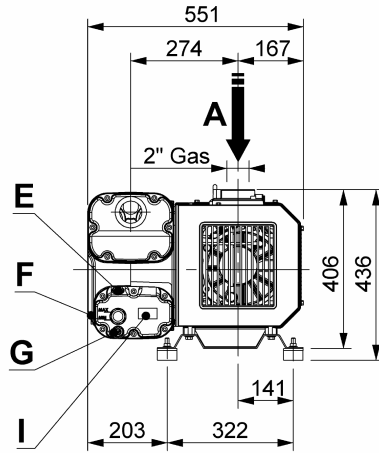
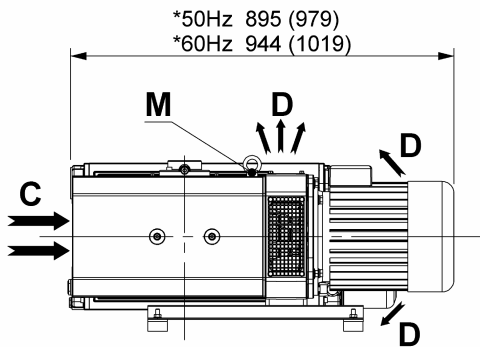

**Misure soggette a variazioni in funzione della marca del motore
*Dimensions subject to changes depending on the motor brand
*Données sujettes aux variations en fonction de la marque du moteur
*Die Maße können aufgrund von Motorzeichen ändern
Medidas sujetas a variación en función de la marca del motor

I

GB

F

D

E

A	Aspirazione	Inlet	Aspiration	Einlass	Aspiración
B	Scarico aria	Exhaust	Sortie de l'air	Luftauslass	Salida de aire
C	Entrata aria raffreddamento	Cooling air inlet	Entrée air refroidissement	Kühlluftseintritt	Entrada aire refrigeración
D	Uscita aria raffreddamento	Cooling air outlet	Sortie air refroidissement	Kühlluftaustritt	Salida aire refrigeración
E	Tappo carico olio	Oil filling plug	Bouchon remplissage huile	Öleinfüllschraube	Tapón carga de aceite
F-F'	Spia livello olio	Oil level sight glass	Voyant niveau huile	Ölschauglas	Mirilla aceite
G	Tappo scarico olio	Oil drain plug	Bouchon vidange huile	Ölablass-Schraube	Tapón vaciado de aceite
H	Targhetta identificazione	Pump name plate	Plaque d'identification	Maschinenschild	Placa de identificación
I	Targhetta oli	Oil grade label	Plaque huiles	Ölempfehlungsschild	Placa tipos de aceites
L	Targhetta rotazione	Rotation plate	Plaque rotation	Drehungsschild	Placa sentido de giro
M	Golfaro di sollevamento	Lifting eyebolt	Anneau de levage	Aufhebenöschraube	Gancho de levantamiento
N	Zavorratore	Gas ballast valve	Lest d'air	Gasballastventil	Valvula gas-ballast
O	Targhetta superfici calde	Hot surfaces name plate	Plaque surfaces chaudes	Typenschild für warme Fläche	Placa superficies calientes
P	Antivibranti	Vibration damper	Pied antivibratoire	Schwingungsdämpfer	Antivibrante
Q	Filtro olio	Oil filter	Filtre huile	Ölfilter	Filtro de aceite



**SCHEDA TECNICA
DATA SHEET
FICHE TECHNIQUE
TECHNISCHE KARTE
ESQUEMA TECNICO**

**EU205 - EU205/B
EU300 - EU300/B**

Pag.: 1/2

Data:
12/12/08

ST1488.01

		EU205		EU205/B	EU300	EU300/B
Portata nominale* Nominal speed* Débit nominal* Nennsaugvermögen* Caudal nominal*	m ³ /h	50Hz	205		300	
		60Hz	245		360	
Pressione finale*(assoluta) Ultimate pressure* (abs.) Pression limite* (abs.) Enddruck* (abs.) Presión final* (abs.)	mbar	0.5		10	0.5	10
	Pascal	50		1000	50	1000
Potenza motore # / Numero di giri Motor power # / Rotational speed Puissance moteur # / Numéro de révolutions Motorleistung # / Drehzahl Potencia motor # / Velocidad de giro	kW	50Hz ~3	4		5,5	
	min ⁻¹		1500			
	kW	60Hz ~3	5,5		7,5	
	min ⁻¹		1800			
Caratteristiche motore elettrico Electric motor characteristics Caractéristiques moteur électrique Motoreigenschaften Características motor eléctrico		50Hz ~3	IM B5 230/400 V±10%		IM B5 400/690 V±10%	
		60Hz ~3	IM B5 275/480 V±10%		IM B5 480/828 V±10%	
Livello di pressione acustica Sound pressure level Niveau de pression acoustique Schalldruckpegel Nivel de presión acústica	dB(A) EN ISO 2151	50Hz	70		71	
		60Hz	72		73	
Pressione max vapore H ₂ O ammissibile Water vapour tolerance Pression de vapeur d'eau maximale admissible Wasserdampfverträglichkeit Presión máxima de vapor de agua admisible	mbar	30				
Quantità vapore H ₂ O ammissibile Water vapour pumping capacity Capacité de pompage de la vapeur d'eau Wasserdampfkapazität Cantidad de vapor de agua admisible	kg/h	3,6			5	
Carica olio Oil capacity Charge d'huile Öfüllmenge Carga de aceite	l	7				
Peso totale / senza motore Total weight / Without motor Poids total / Sans moteur Gesamtgewicht / Gewicht ohne Motor Peso total / Sin motor	kg	50Hz	161 / 126		188 / 141	
		60Hz	171 / 126		192 / 141	
*Secondo accordi PNEUROP 6602. *According to Pneurop standard 6602. *Selon la norme Pneurop 6602 *Nach der Pneurop Norm 6602. *Según la normativa Pneurop 6602.		#Valido per temperature fino a 40°C e altitudini inferiori a 1000 m. #Valid for temperatures up to 40°C and altitudes lower than 1000 m. #Valable pour températures jusqu'à 40°C et pour altitudes inférieurs à 1000 m. #Gültig für Temperaturen bis 40°C und für Höhen weniger als 1000 m. #Válido para temperaturas hasta 40°C y altitudes inferiores a 1000 m.				

