

Pompa tipo GP-GP/M 45K-65K

Pump type GP-GP/M 45K-65K



- 1 ASPIRAZIONE
- 2 SCARICO
- 3 TAPPO SCARICO OLIO
- 4 SPIA LIVELLO OLIO
- 5 TAPPO CARICO OLIO

- 1 SUCTION
- 2 DISCHARGE
- 3 OIL DISCHARGE PLUG
- 4 OIL SIGHT GLASS
- 5 OIL FILL UP PLUG

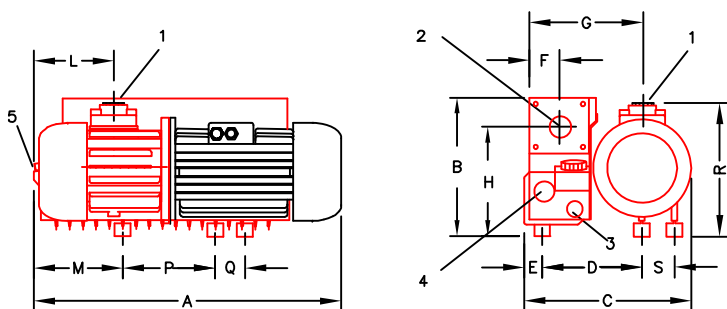

		Tipo di pompa/Frequenza Pump type/Frequency							
		GP45K 50Hz	GP45K 60Hz	GP/M45K 50Hz	GP/M45K 60Hz	GP65K 50Hz	GP65K 60Hz	GP/M65K 50 Hz	GP/M65K 60Hz
Dimensioni (mm) Dimensions (mm)	A	500	500	500	500	500	500	500	500
	B	265	265	265	265	265	265	265	265
	C	350	350	350	350	350	350	350	350
	D	250	250	250	250	250	250	250	250
	E	25	25	25	25	25	25	25	25
	F	75	75	75	75	75	75	75	75
	G	260	260	260	260	260	260	260	260
	H	210	210	210	210	210	210	210	210
	L	160	160	160	160	160	160	160	160
	M	150	150	150	150	150	150	150	150
	P	175	175	175	175	175	175	175	175
	Q	80	80	80	80	90	90	90	90
	R	260	260	260	260	260	260	260	260
S	60	60	60	60	60	60	60	60	

50Hz

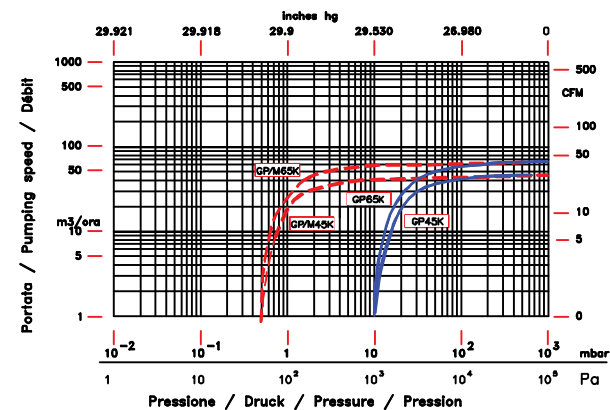

60Hz

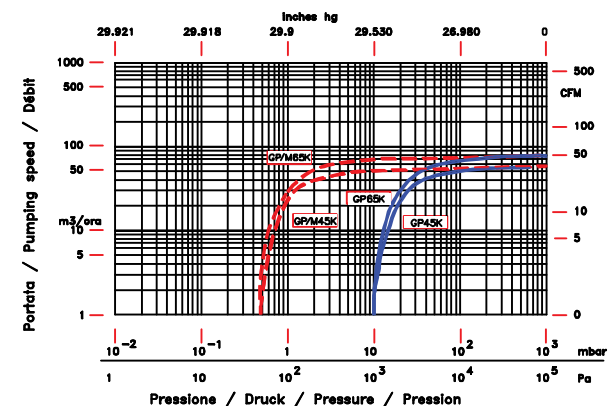

			Tipo di pompa/Frequenza Pump type/Frequency							
			GP45K 50Hz	GP45K 60Hz	GP/M45K 50Hz	GP/M45K 60Hz	GP65K 50Hz	GP65K 60Hz	GP/M65K 50 Hz	GP/M65K 60Hz
Portata nominale	Displacement	m³/h	45	54	45	54	65	78	65	78
Vuoto finale	Ultimate vacuum	mbar	10	10	0,5	0,5	10	10	0,5	0,5
Rumorosità media senza zavorratore	Noise level without gas ballast	db (A)	58	60	58	60	58	60	58	60
Vuoto finale con zavorratore	Ultimate vacuum with gas ballast	mbar	14	14	1,5	1,5	14	14	1,5	1,5
Quantità max di vapore d'acqua tollerabile con zavorratore	Max water vapour quantity acceptable with gas ballast	kg/h	0,3	0,7	0,3	0,7	1	1,2	1	1,2
Tensione standard	Standard voltage	V	230/400	460	230/400	460	230/400	460	230/400	460
Potenza motore	Motor power	kW	1,5	1,5	1,5	1,5	1,5	1,8	1,5	1,8
Velocità di rotazione	R.P.M.	g/1'	1450	1750	1450	1750	1450	1750	1450	1750
Peso con olio	Weight with oil	kg	42	42	42	42	48	48	48	48
Quantità d'olio (min/max)	Oil quantity (min/max)	l	1,5/2	1,5/2	1,5/2	1,5/2	1,5/2	1,5/2	1,5/2	1,5/2
Attacco aspirazione	Inlet connection		1" GAS	1" GAS	1" GAS	1" GAS	1" GAS	1" GAS	1" GAS	1" GAS
Attacco scarico	Outlet connection		1¼" GAS	1¼" GAS	1¼" GAS	1¼" GAS	1¼" GAS	1¼" GAS	1¼" GAS	1¼" GAS